

All reproduction & intellectual property rights reserved c 2010

TENANT IMPROVEMENT:
BAY AREA ROOFERS & WATERPROOFERS TRAINING CENTER
420 LEISURE STREET
LIVERMORE, CA 94550

PREPARED FOR:
NORTHERN CALIFORNIA ROOFERS LABOR MANAGEMENT TRUST
1425 TREAT BLVD., SUITE C
WALNUT CREEK, CA 94596

In association with:

MBA STRUCTURAL ENGINEERS
STRUCTURAL
1717 N. CALIFORNIA BLVD. #3C
WALNUT CREEK, CA 94596

ELOCIN CONSTRUCTION COMPANY
ELECTRICAL
4861 SUNRISE DRIVE, #108
MARTINEZ, CA 94553

DELCON MECHANICAL
52 WRIGHT BROTHERS AVE
LIVERMORE, CA 94551

KDS PLUMBING
PLUMBING
2087 RINGWOOD AVE, #10
SAN JOSE, CA 95131

Professional seals

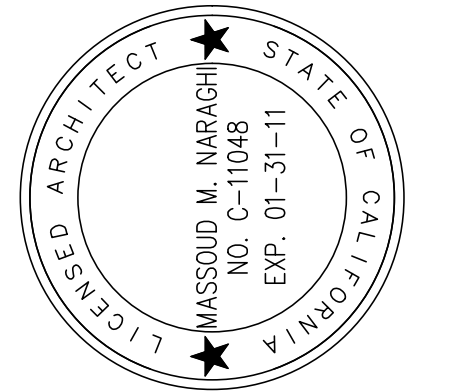

No.	Issue Description	Date
1	PLAN CHECK	06/01/2010

Drawn by: K.NARAGHI Reviewed by: M.NARAGHI

Project No: 030409-01RWA

A9.3.dwg
Sheet Titles:

CEILING DETAILS

Original drawing is 24" x 36". Scale entities accordingly if reduced.
Sheet Number:

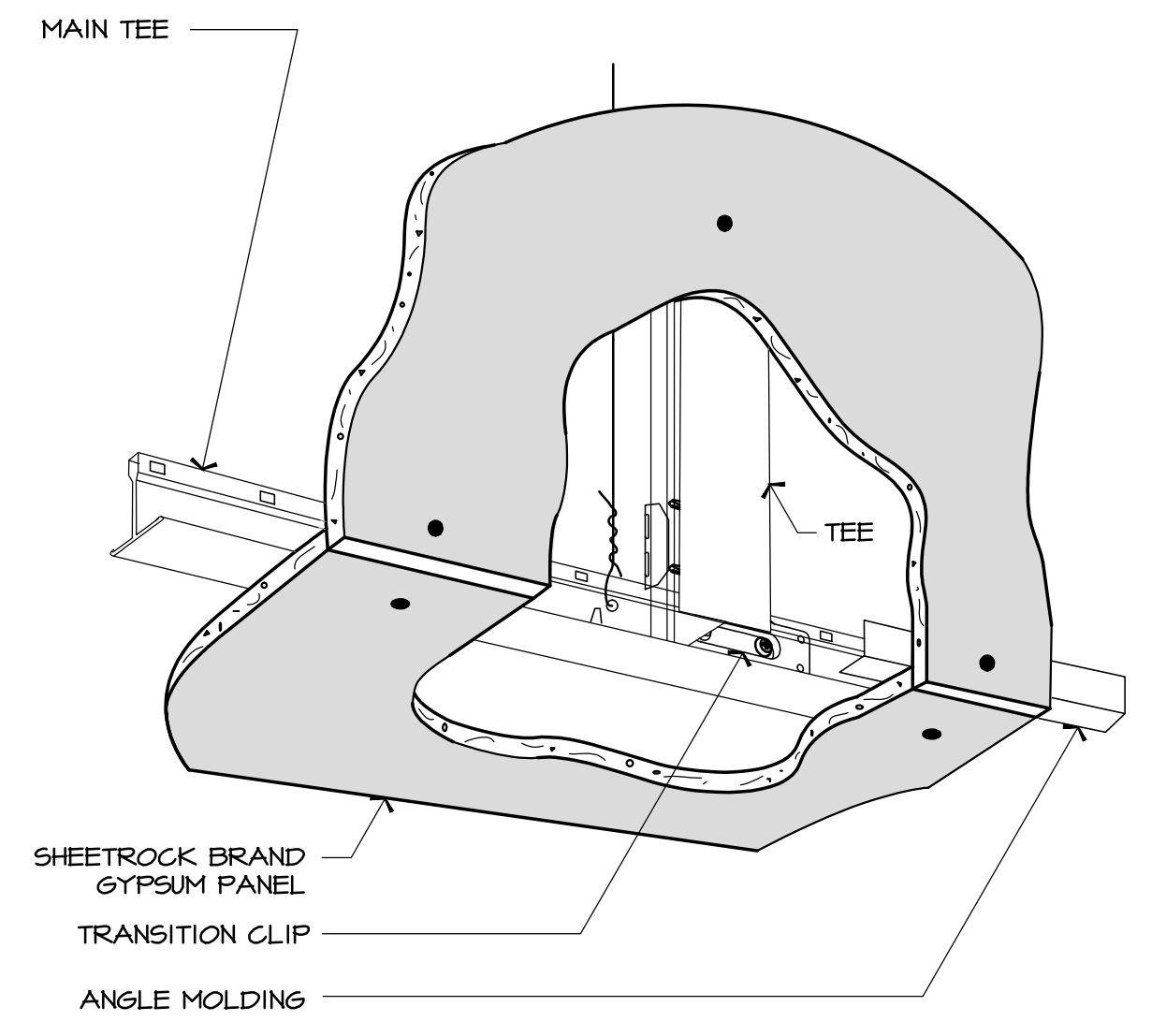

1 OUTSIDE CORNER DETAIL
CLG-CORNER WITH MAIN TEES.DWG SCALE: N.T.S.

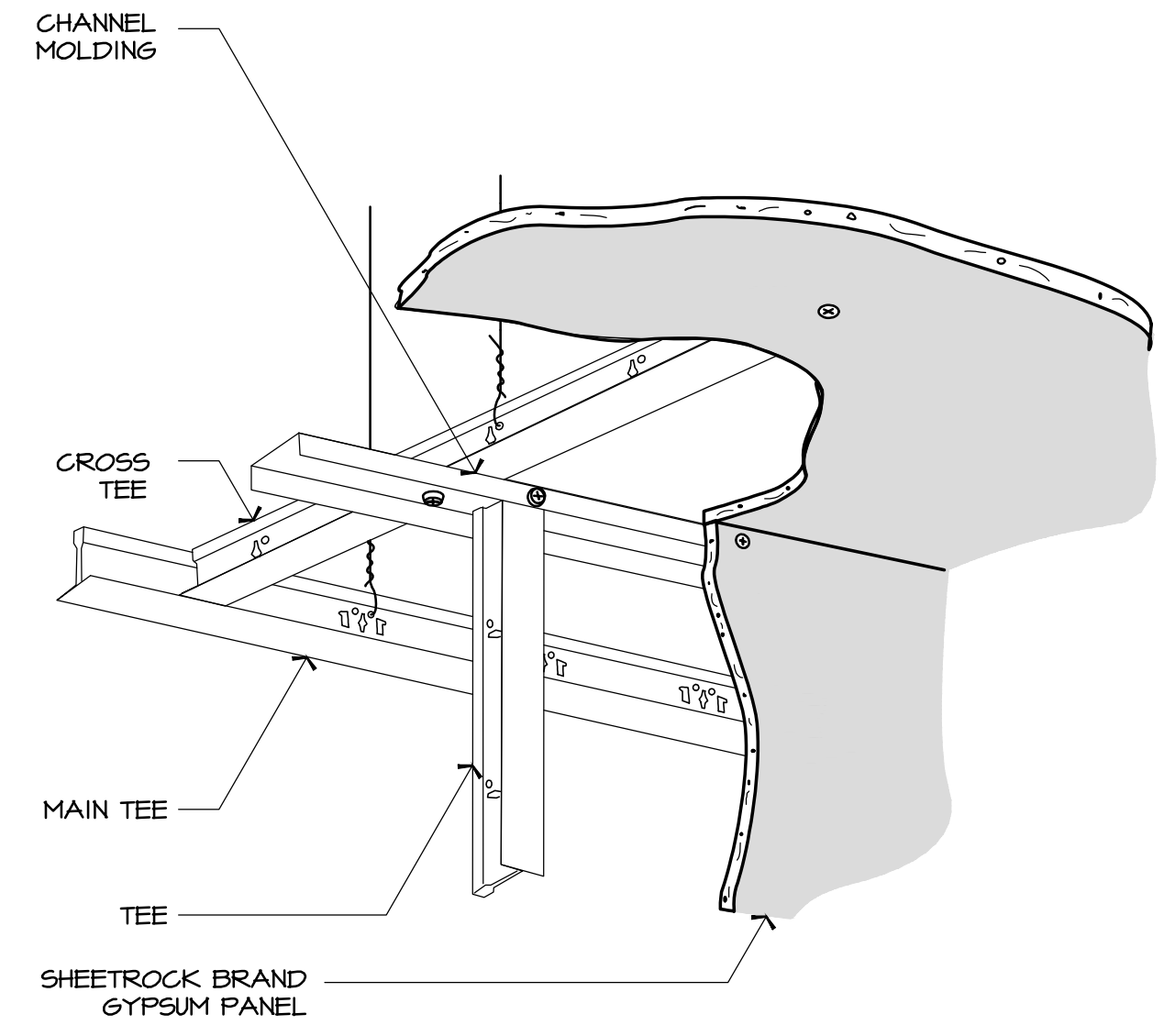

4 INSIDE CORNER WITH CHANNEL
CLG-CORNER WITH CHANNEL MOLDING.DWG SCALE: N.T.S.

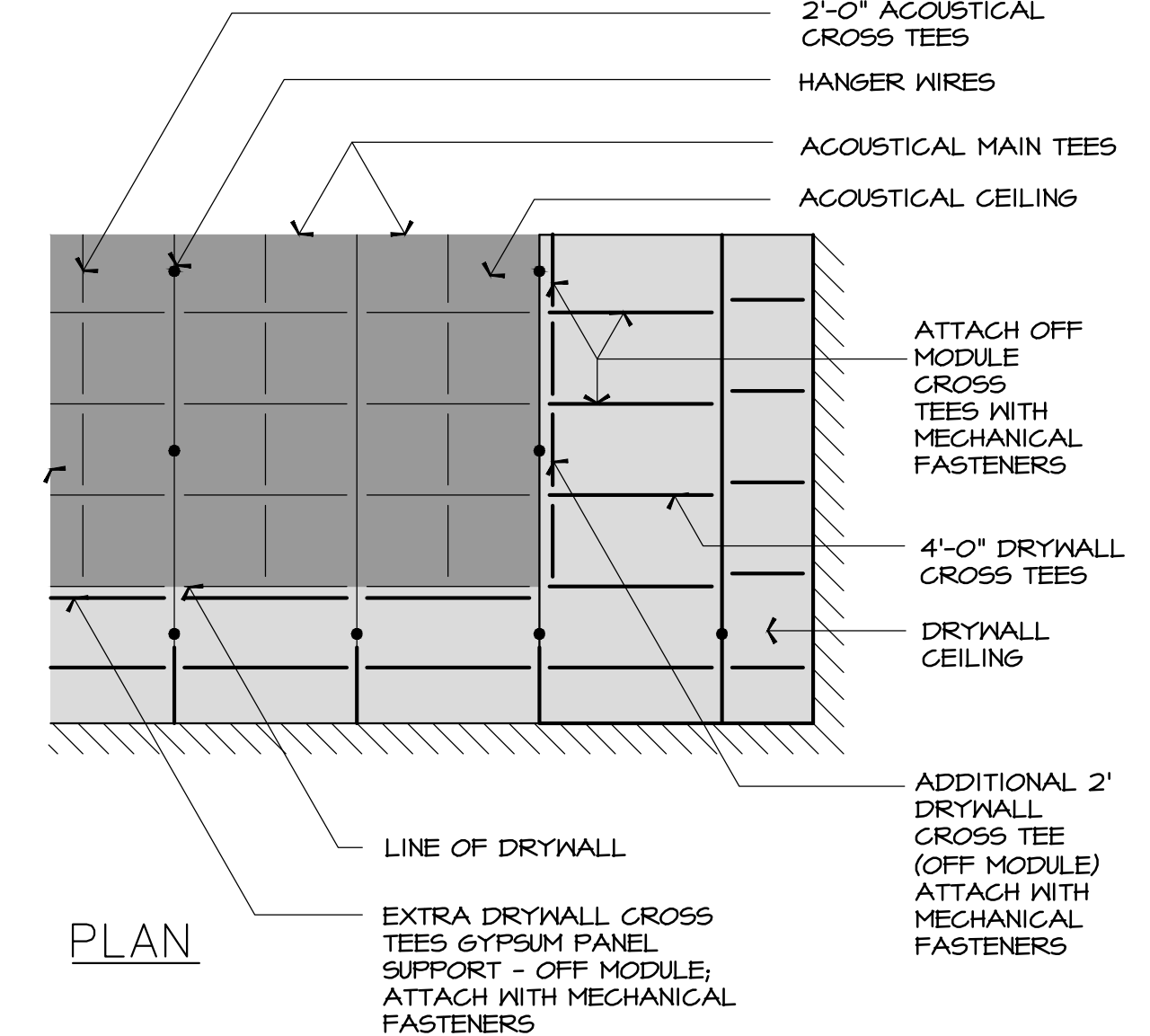

7 DRYWALL-ACOUSTICAL TRANS.
CLG-PLAN VIEW.DWG SCALE: N.T.S.

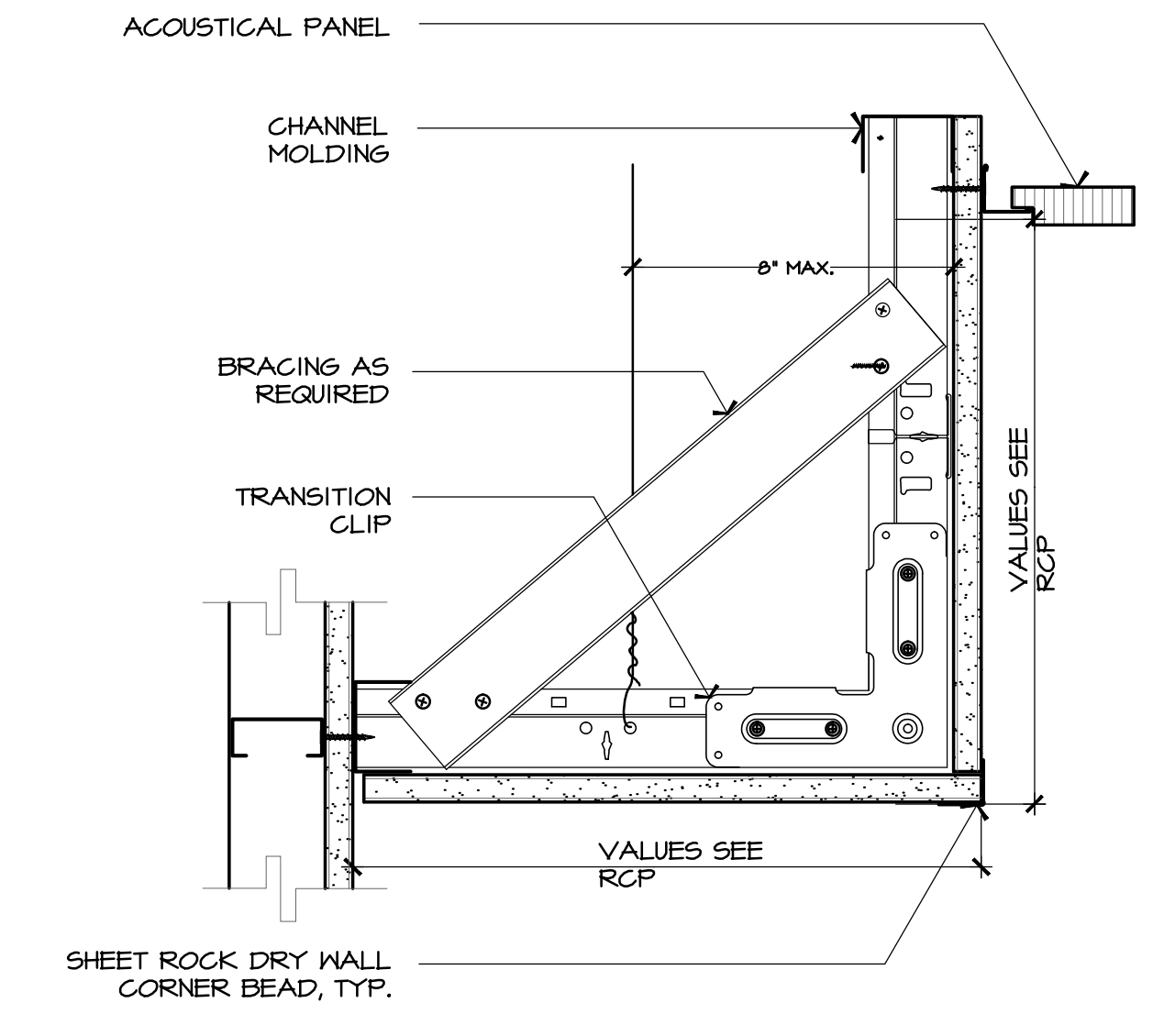

10 SOFFIT & ACOUSTICAL DET.
CLG-SOFFIT AND ACOUSTICAL TRANSITION.DWG SCALE: N.T.S.

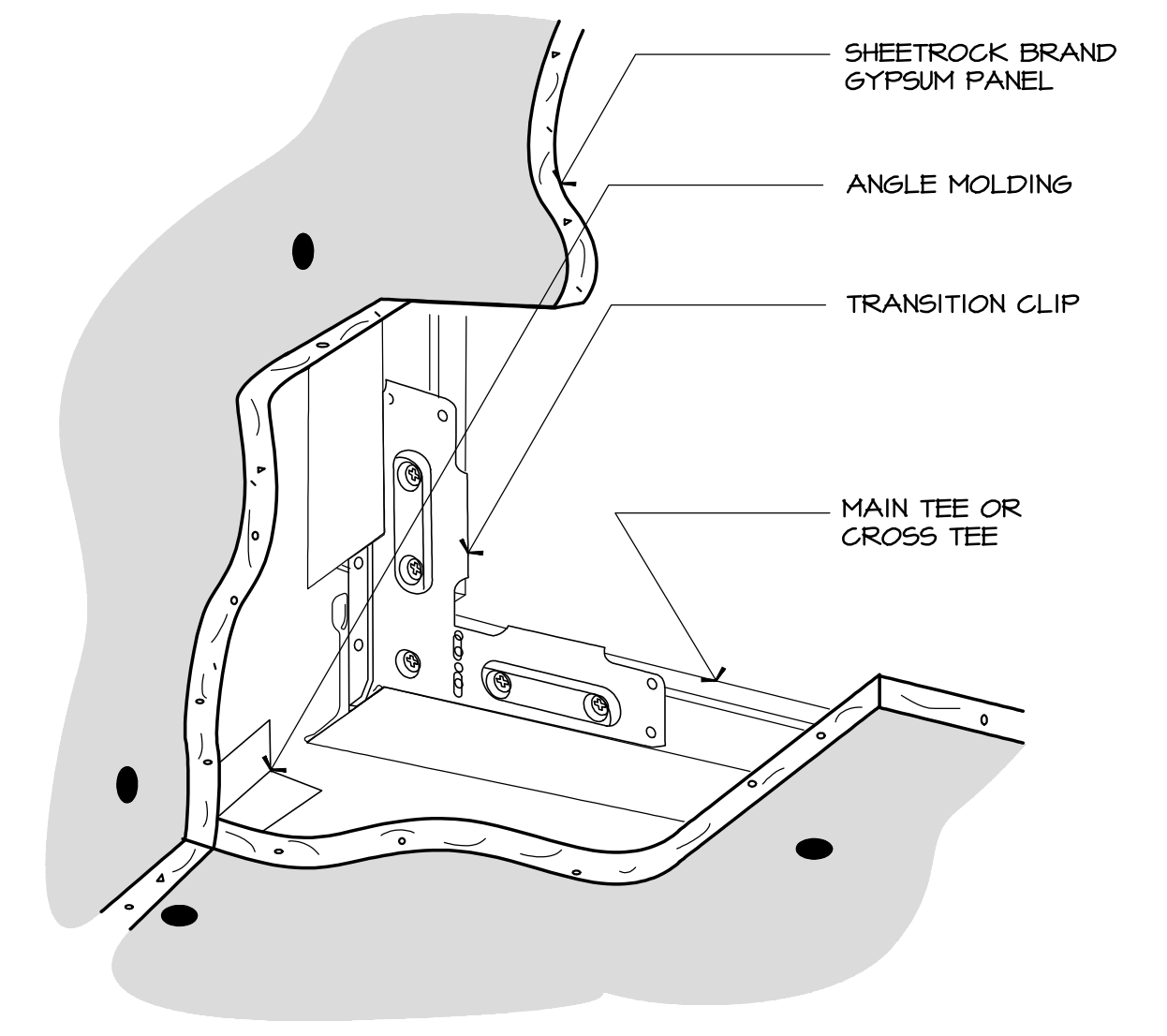

2 CORNER - TRANSITION CLIP
CLG-CORNER USING TRANSITION.DWG SCALE: N.T.S.

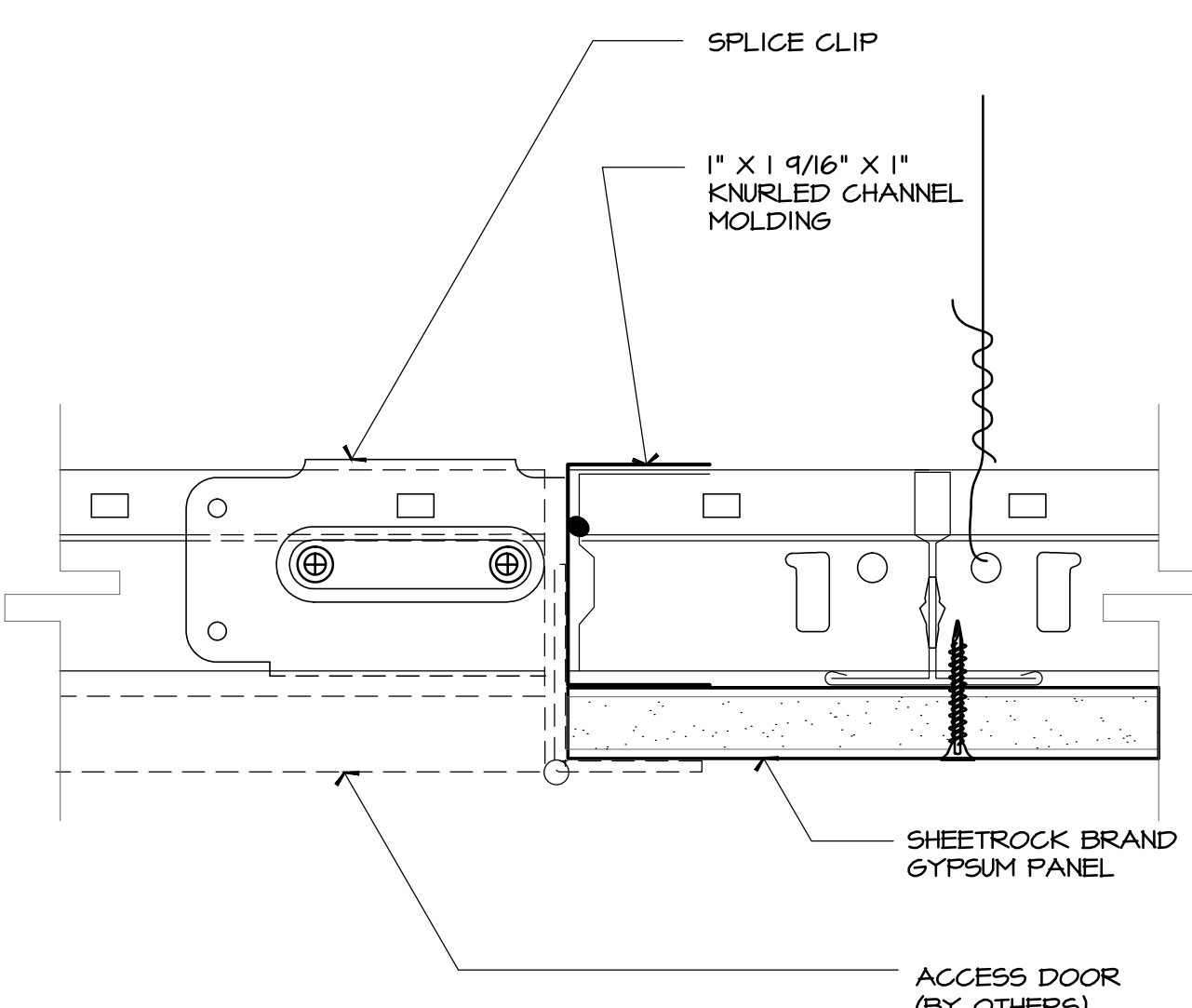

5 ACCESS DOOR DETAIL
CLG-ACCESS DOOR.DWG SCALE: N.T.S.

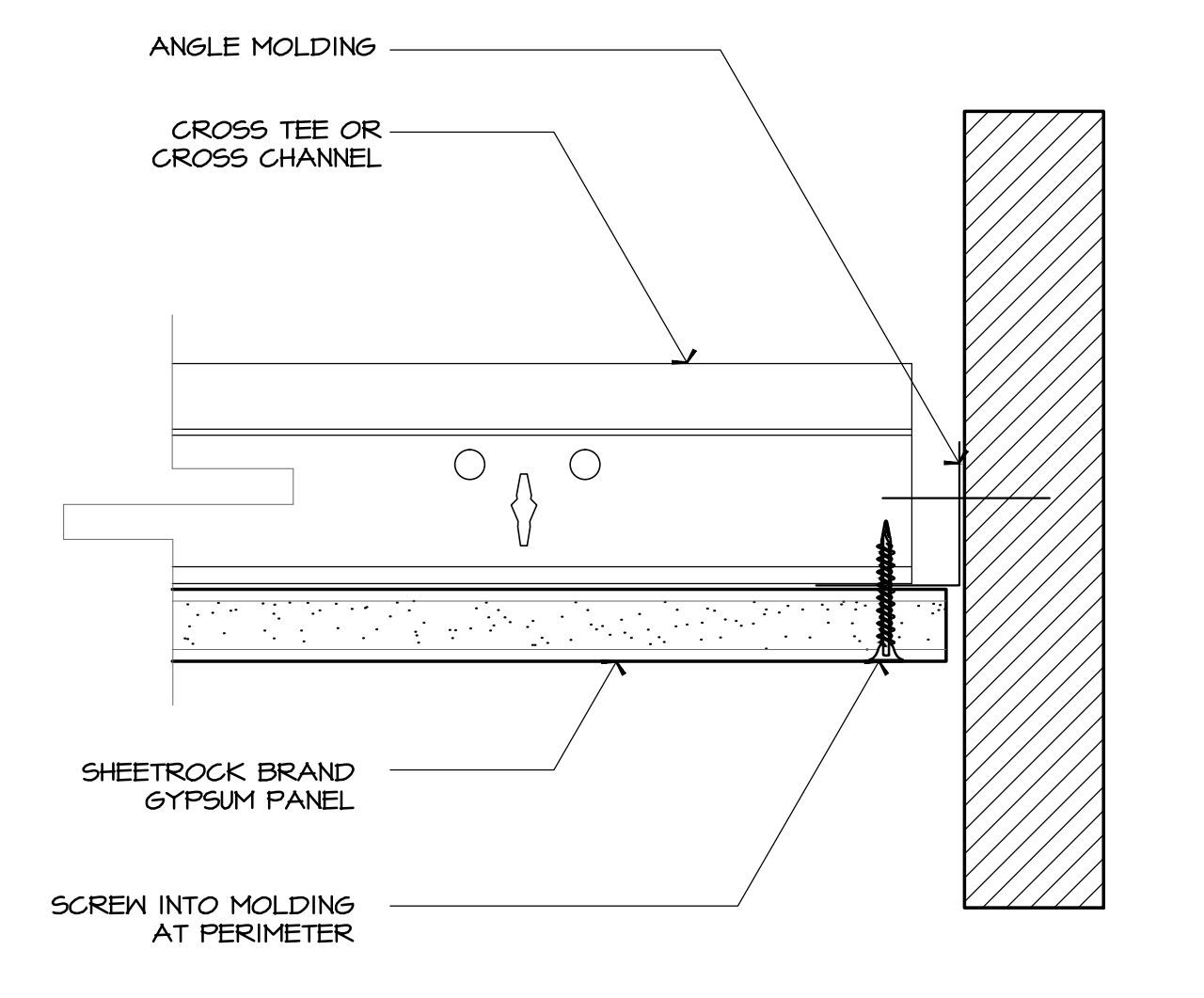

8 ANGLE MOLDING DETAIL
CLG-ANGLE MOLDING.DWG SCALE: N.T.S.

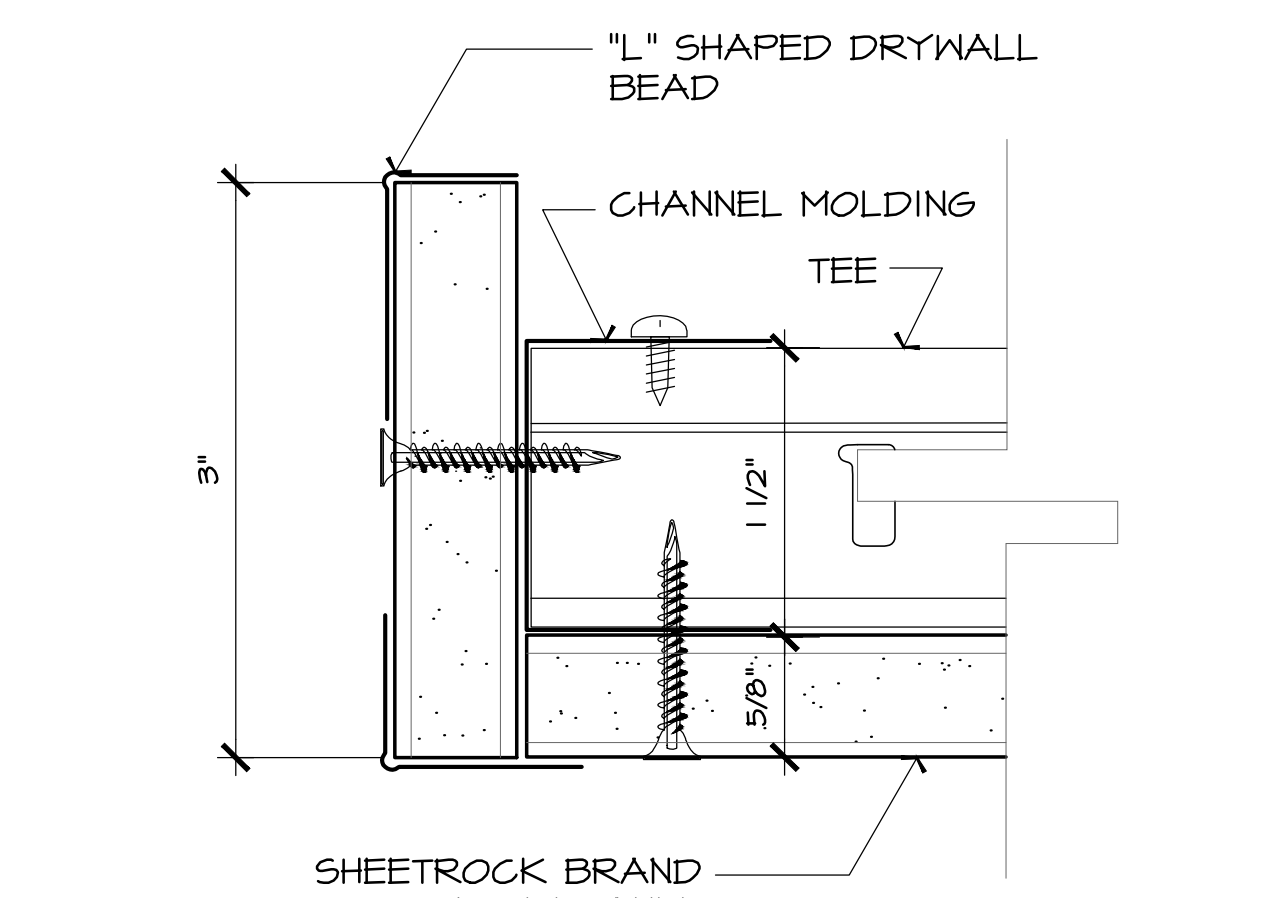

11 DETAIL @ GYP. BD. EDGE
CLG-DETAIL-GYPEDGE.DWG SCALE: N.T.S.

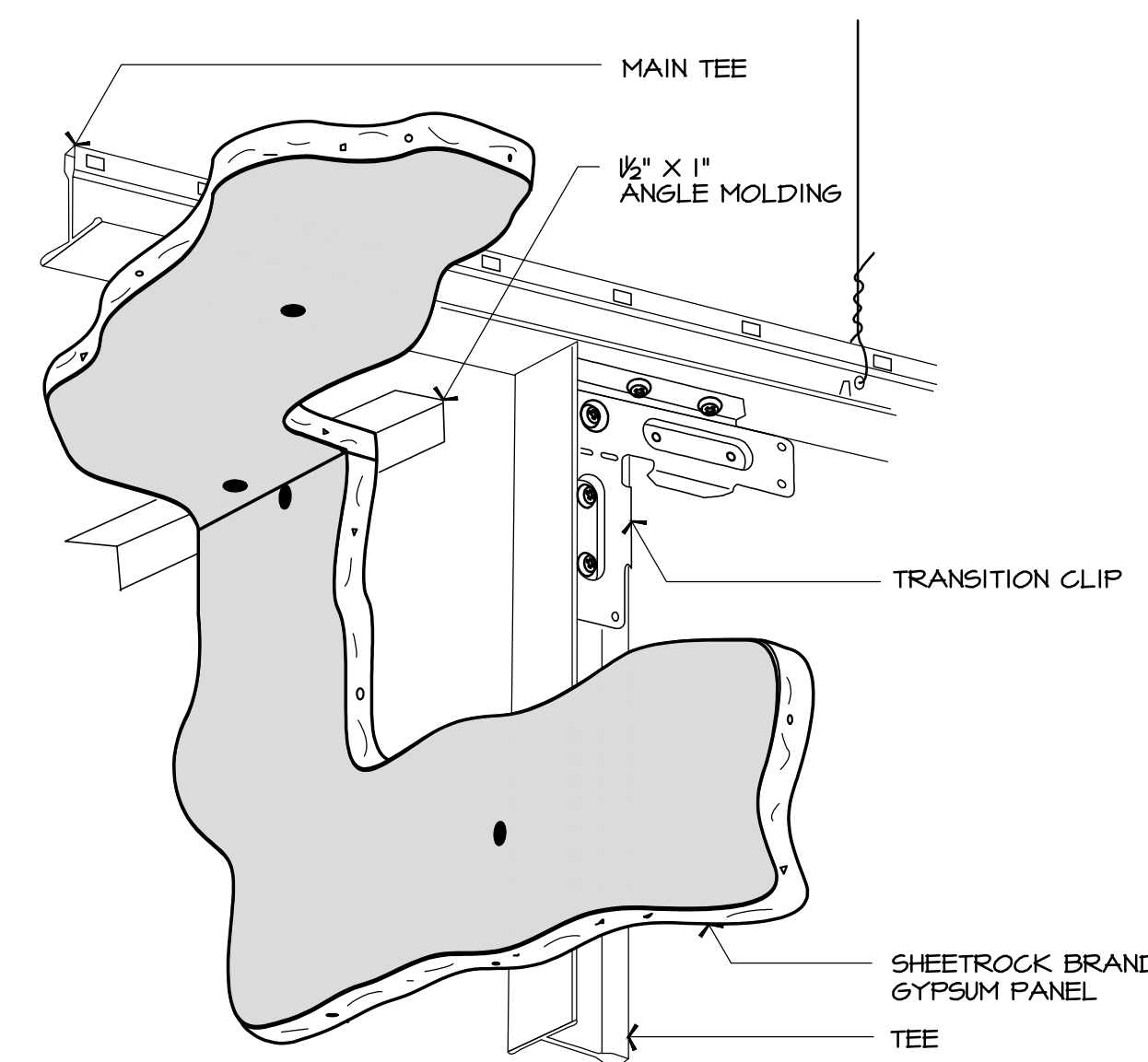

3 CORNER WITH FIELD CUT TEE
CLG-CORNER FIELD CUT TEES.DWG SCALE: N.T.S.

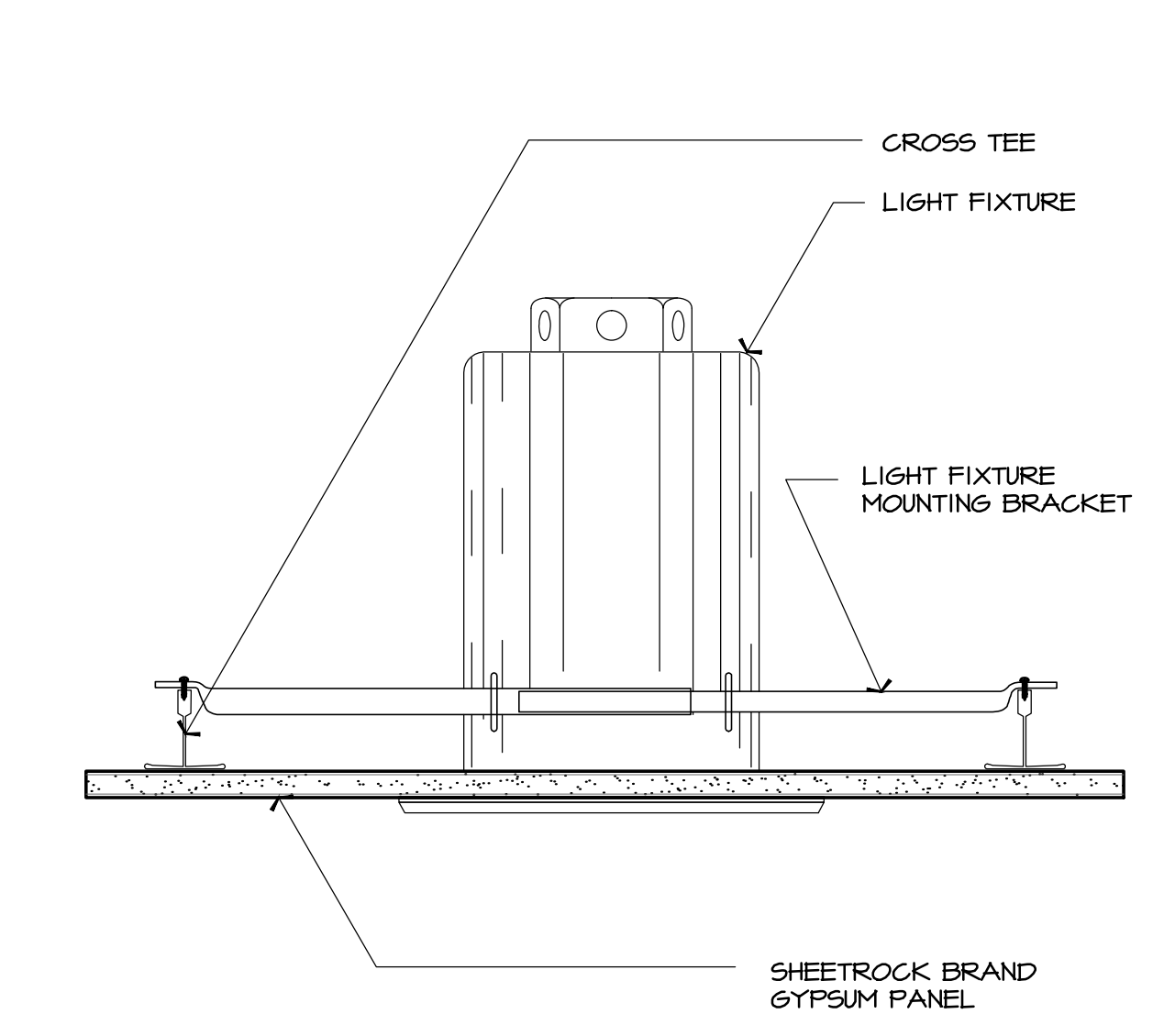

6 RECESSED LIGHT FIXTURE
CLG-RECESSED-LIGHT.DWG SCALE: N.T.S.

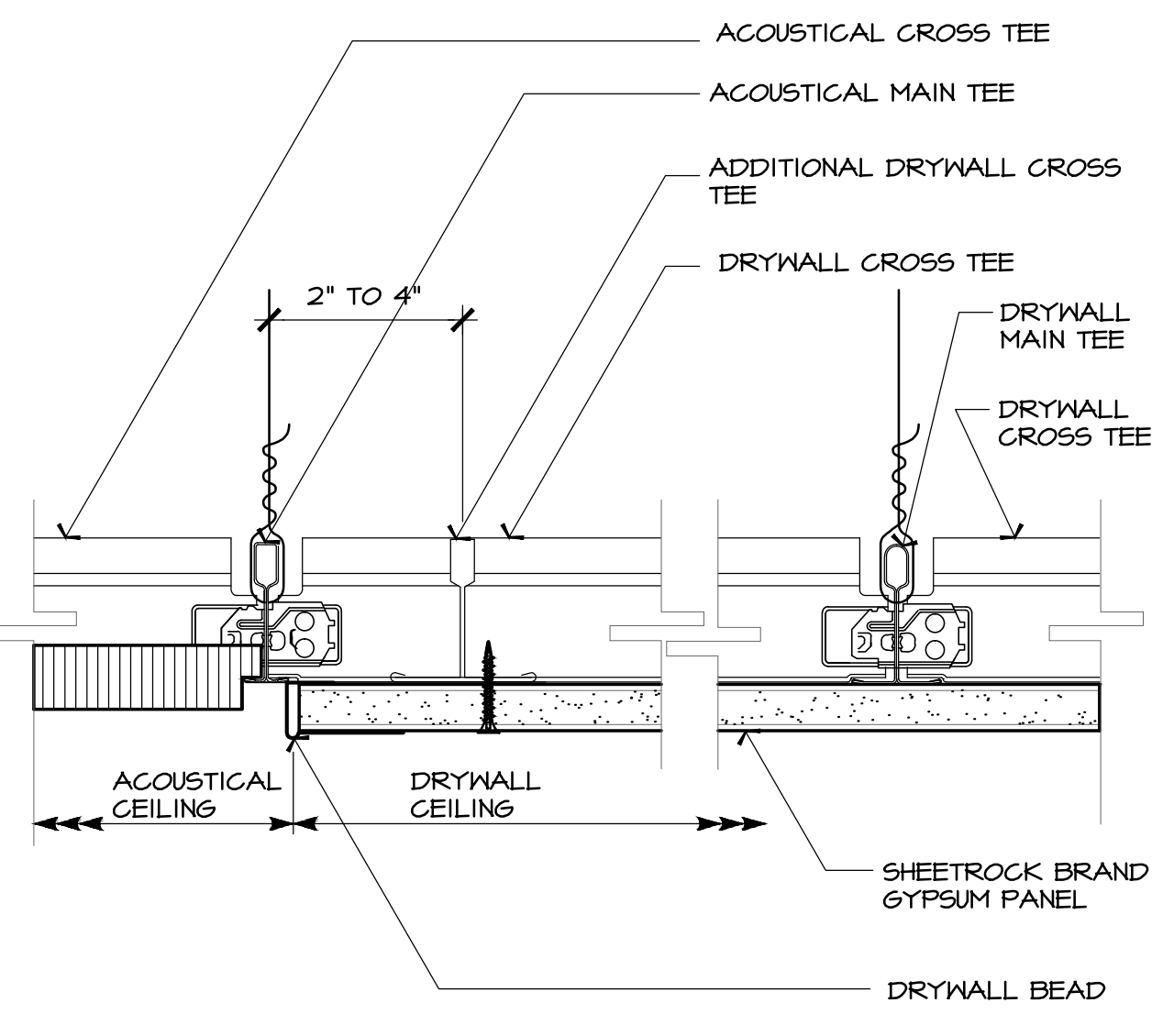

9 DRYWALL - ACOUSTICAL DET.
CLG-DRYWALL-ACOUSTICAL TRANSITION.DWG SCALE: N.T.S.

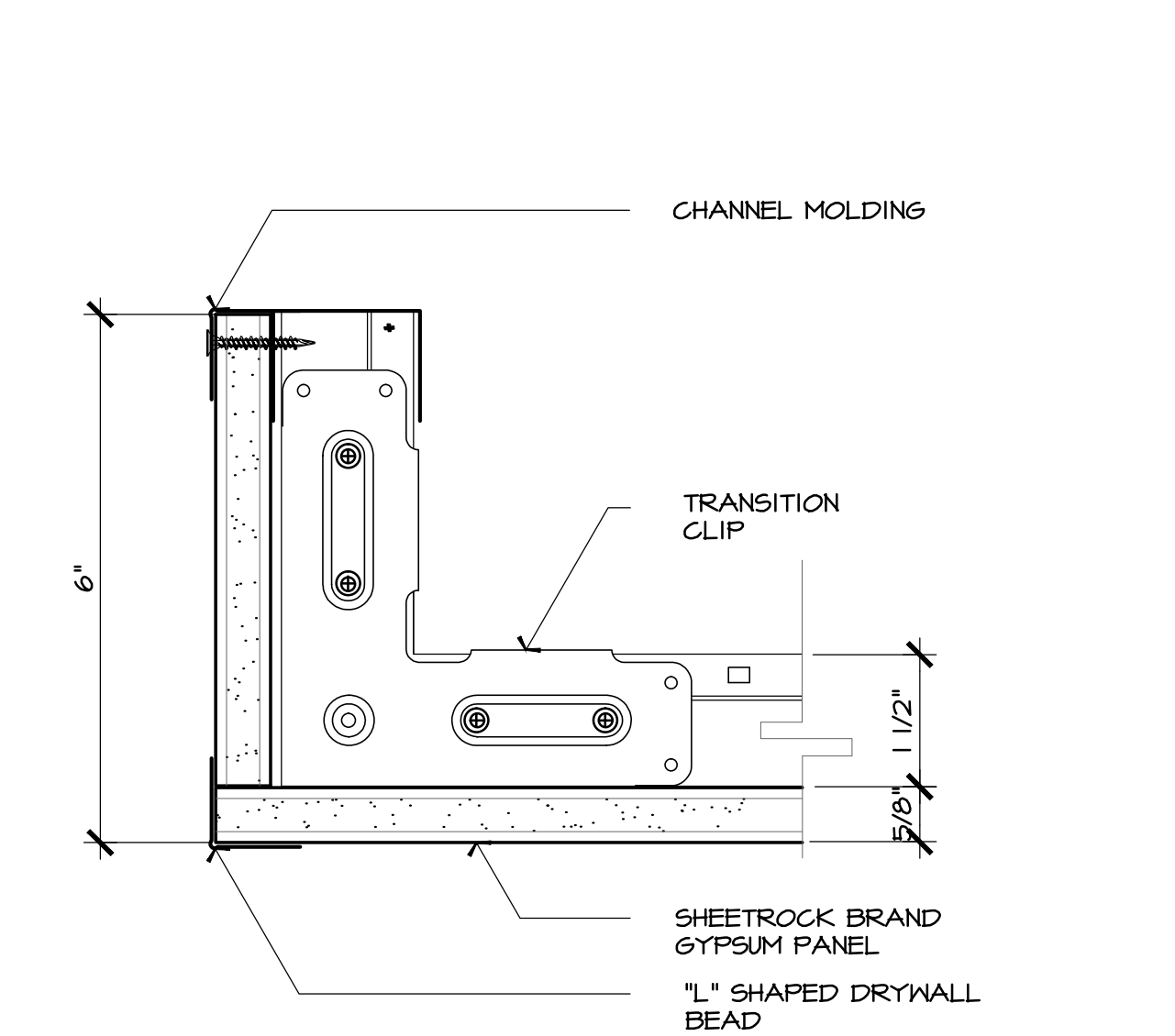

12 DETAIL @ TRANSITION DETAIL
CLG-DETAIL-TRANSITION.DWG SCALE: N.T.S.